



First on the North American Continent and now world-wide, we at Formglas take pride that, for over 30 years our products have been considered among the best. That we are the largest custom manufacturer of Glass-fiber Reinforced Gypsum (G.R.G.) in the world is no coincidence. A dedicated staff is committed to quality and management's construction background guarantees customers that all parts are engineered for smooth and safe installation. A worldwide network of branches and agents ensures optimum service to Architects, Designers, and Contractors. In good times and bad, Formglas' strong financial and market position has afforded it never to reduce its investment in R & D to continuously improve its products. This brochure gives only a glimpse of the unlimited G.R.G. possibilities. When you specify Formglas products, you will incorporate the best material available.



FORMGLAS G.R.G.

Formglas* G.R.G. (Glassfiber Reinforced Gypsum) was developed to allow Architects and Designers to incorporate complex or simple elements that lend an exciting dimension to interior spaces.

A composition of high strength gypsum reinforced with glassfibers, it is factory molded into any shape or size. The parts are totally non-combustible, and even the largest parts weigh only 2-3 lbs/sq.ft. (10-15kg/sq.m.) and can be field finished with any interior paint (high gloss is not recommended).

Most projects are custom engineered and manufactured. Comprehensive Formglas shop drawings show not only shapes and dimensions, but will also indicate fastening and hanging methods. Although no parts are stocked, there are many existing molds that can be used to manufacture columns, moldings, etc.

Production facilities in Toronto, Canada and Kuala Lumpur, Malaysia employ over 200 people including Architects, Engineers and expert craftsmen to ensure that our parts are accurately engineered and made.

Because of its light weight and ease of installation, costs will be less than similar products or traditional plaster and other trades can continue working while the G.R.G. is going up.

All molds are generated by the most advanced CNC equipment available, resulting in parts that are unmatched in quality. Our on-time delivery, even for the largest projects, is considered the best in the industry.

Factory representatives are available to assist in finding cost effective design solutions. A worldwide agent network including a Sales/Engineering office in Tokyo, ensures expert advice anywhere.

Since 1961, Formglas* products have proven to be the very best available.



FORMGLAS (TORONTO, CANADA)
COVER PHOTO - NEWLANDS BUILDING (BETHESDA, MD)

Please Visit our Website
www.formglas.com

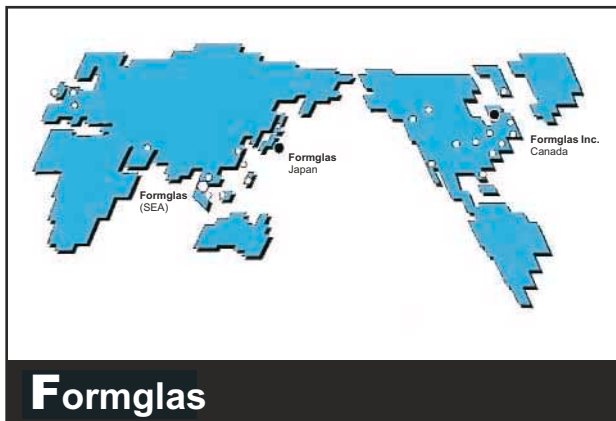

Formglas Inc.

20 Toro Road, Toronto, ON CANADA M3J 2A7
Tel: (416) 635-8030 Fax: (416) 635-6588
Web Site: <http://www.formglas.com>

Formglas (SEA) Sdn Bhd.

Lot 590, Persiaran Raja Luma Pandamaran Ind. Area,
42000 Port Klang, Selangor Darul Ehsan, MALAYSIA
Tel: (603) 368-1299 Fax: (603) 367-7795

Formglas Japan Inc.

1-10-4 Shinjuku Shinjuku-Ku, Tokyo 160, JAPAN
Tel: (03) 3225-8397 Fax: (03) 3225-9153



U.S. MINT BUILDING, WASHINGTON D.C.



FOSTERS COURT • ROWES WHARF (BOSTON)

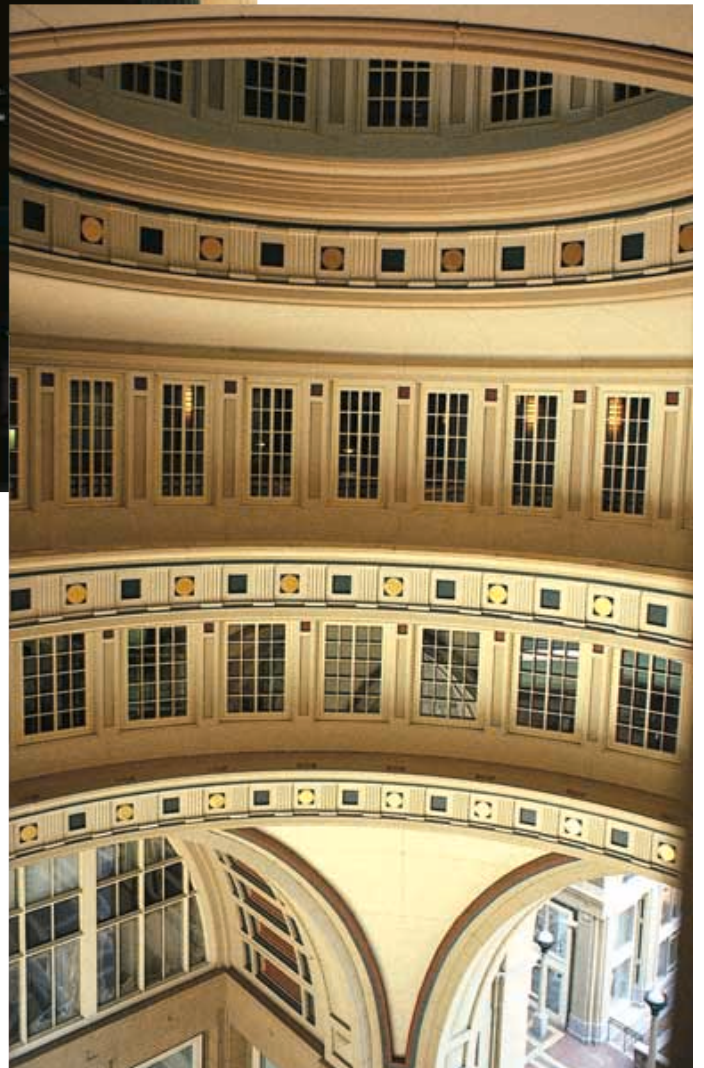

ROWES WHARF HOTEL
RESTAURANT (BOSTON)





WESTIN HOTEL CHAPEL (TOKYO, JAPAN)



KING EDWARD HOTEL
LOBBY (TORONTO)



KING EDWARD HOTEL
BANQUET HALL (TORONTO)



EATON SHOPPING CENTER • FOOD COURT (HAMILTON)

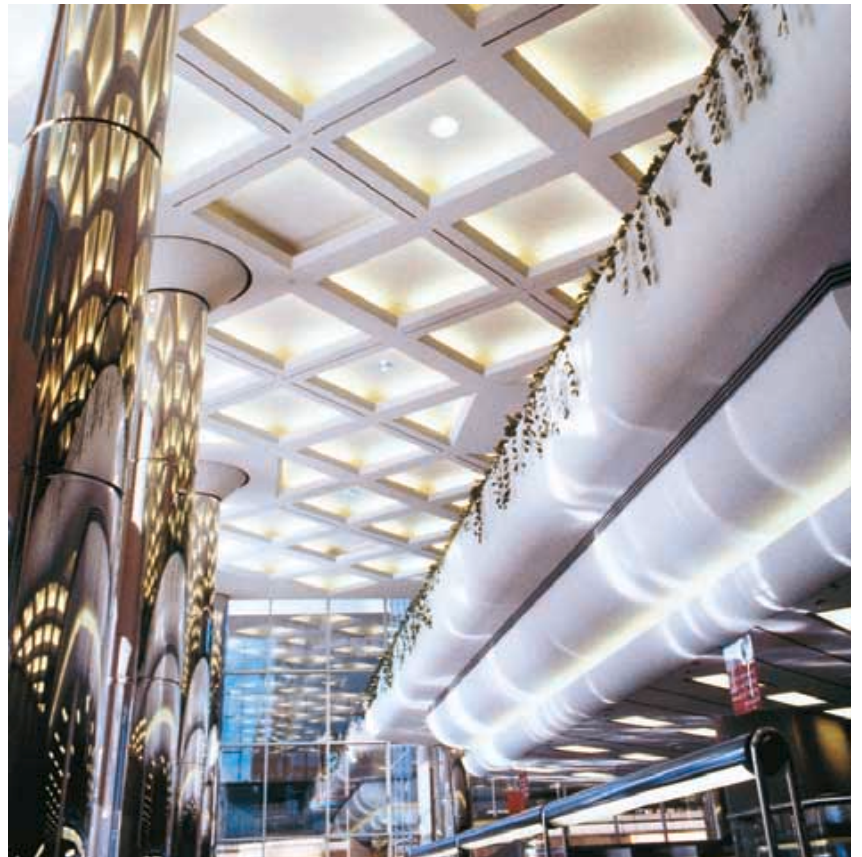

CIBC HAMILTON)



FORMGLAS SHIPS ACROSS THE CONTINENT



OR AROUND THE WORLD



MATERIAL READY FOR SHIPPING

Installation Tips



A FACTORY MOCK UP OF A COMPLEX DOME
(NOTE THE MAN STANDING ON TOP)

- The Formglas* companies do not install but will gladly recommend experienced installer names or installation procedures.
- Formglas* G.R.G. elements are strong, amazingly lightweight and normally lifted and installed by one or two persons.
- Thickness: 1/8" - 3/16" (3-5 mm) with thicker edges
Weight: 2-3 lbs/sq.ft. (10-15 kg/sq.m)
- Ceiling elements are usually suspended. Most other parts are face fastened with screws (countersunk and filled) through "built-in" reinforcing strips.
- Moldings, normally (2400 mm) long can be supplied with factory molded corners or field mitered. Any type of mechanical or hand saw can be used for field cutting, but because of the glass fibers, carbide tipped blades are recommended. Cutting dust is not a health hazard.
- The framing/back up systems and fastening points are normally less frequent that for gypsum board.
- For a continuous look, joints are taped and field painting is the same as for gypsum board. (Alkyd/oil based primers are recommended, but high gloss paints should be avoided.)
- Elements can be made in all shapes and sizes, but transport and handling conditions may make very large parts impractical.
- Being non-combustible, fire authorities are always glad to see Formglass* G.R.G. on the job.

VICTORIA AIRPORT (VICTORIA B.C.)



STOCK EXCHANGE (TORONTO)



NORDSTRUMS STORE • WALNUT CREEK (CALIFORNIA)



FORMGLAS AND GYPSUM BOARD
CEILINGS ARE TAPED AT THE SAME TIME.



EATON SHOPPING CENTER • FOOD COURT (HAMILTON)

Design Suggestions

- Use the same shape as often as possible or one from our existing mold inventory, every shape, including each curve or radius requires its own mold. Molds will add to costs and delivery times.
- Parts can be made in near any shape or size but transport, site access and handling problems may make very large parts impractical.
- Large flat surfaces are often more economical in drywall while very small moldings may be less expensive in wood.
- For a continuous look, joints can be (field) taped while a "broken-up" appearance can be achieved with reveals or caulked joints. Always allow for manufacturing and field tolerances at the joints.
- Very small reveals or projections less than 1/4" (6mm) "stand alone" elements work well but these small features can be difficult to line up and/or tape (on site) from one part to the next.
- Formglas® G.R.G. is non-combustible but is not "hourly rated".
- It can be used in high humidity climates and in "rain" protected exterior soffits.
- All elements are "made to order" and a standard price list is not available. Send us a sketch with the required quantities and Formglas will supply pricing within a few days.
- Specify Formglas® products to ensure quality and "on time" delivery.

Details

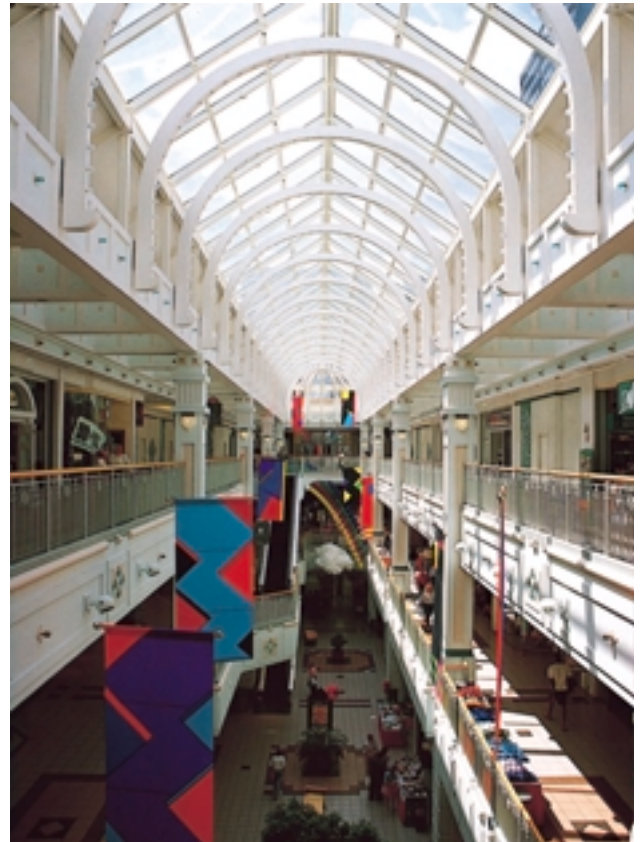

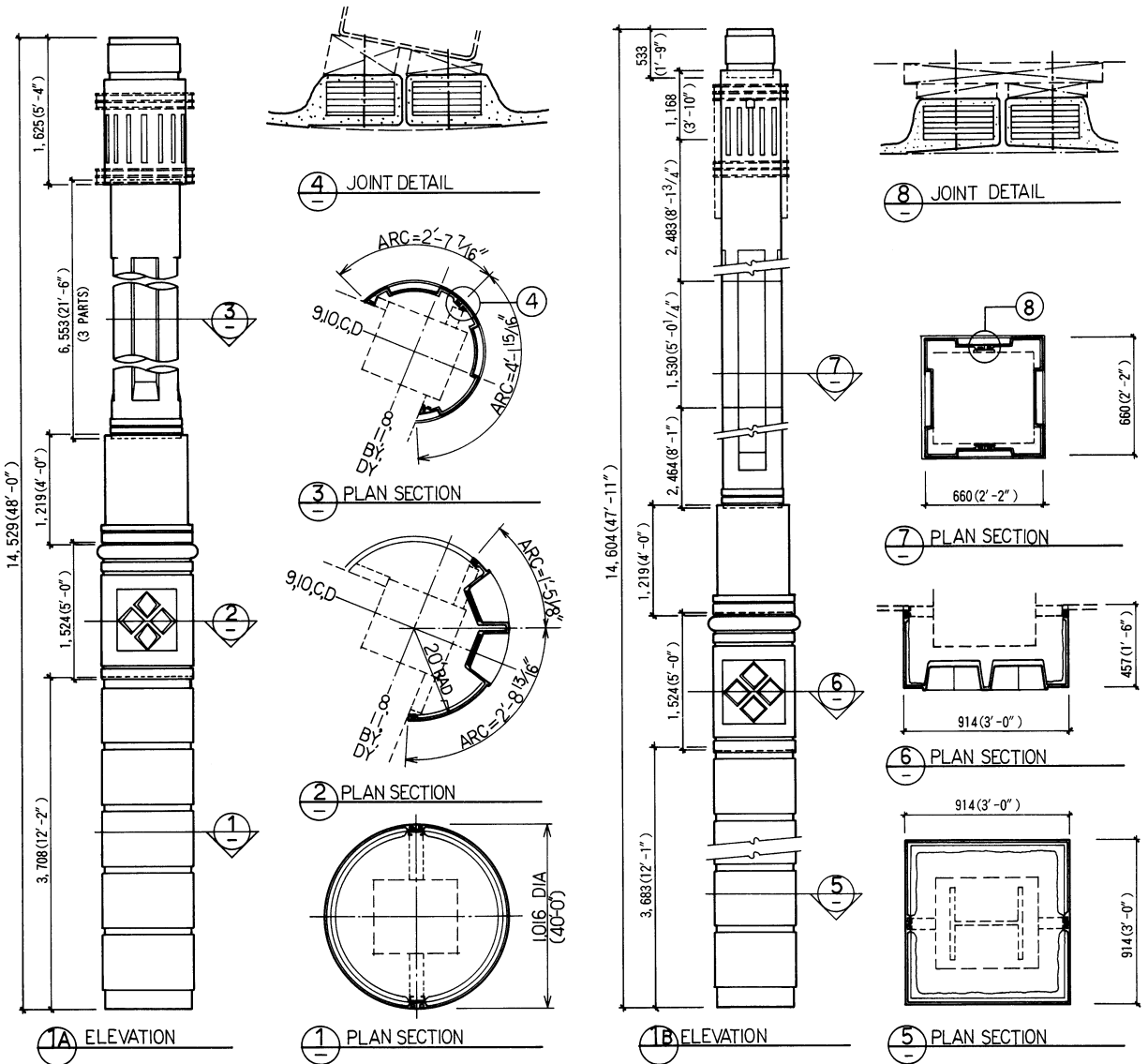
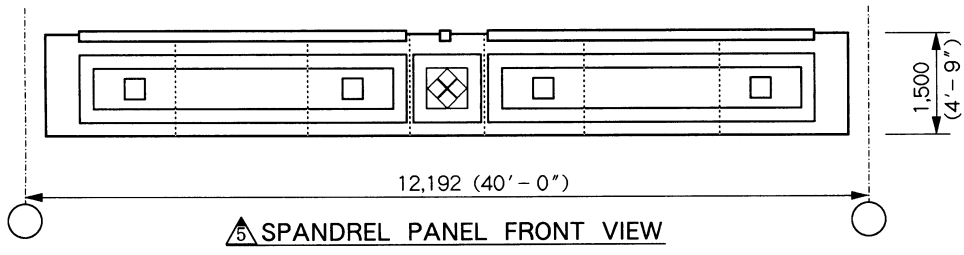
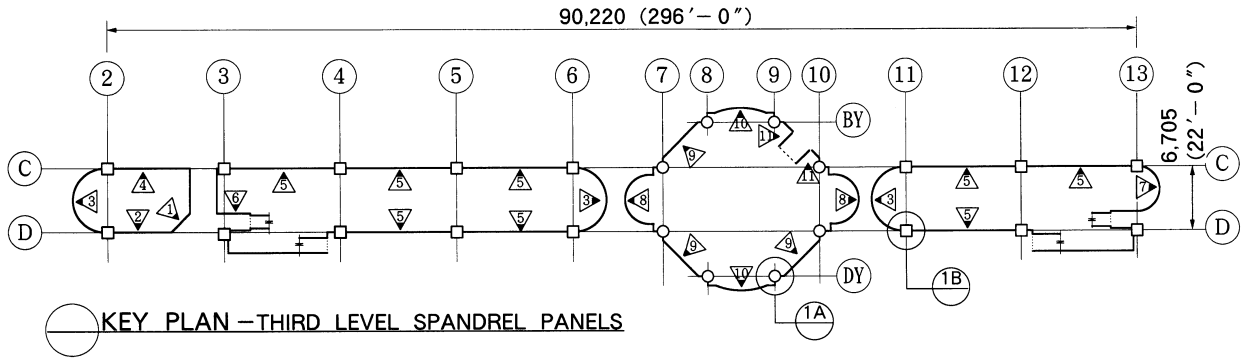



BELL CANADA ENTERPRISES PALCE (TORONTO)



Details

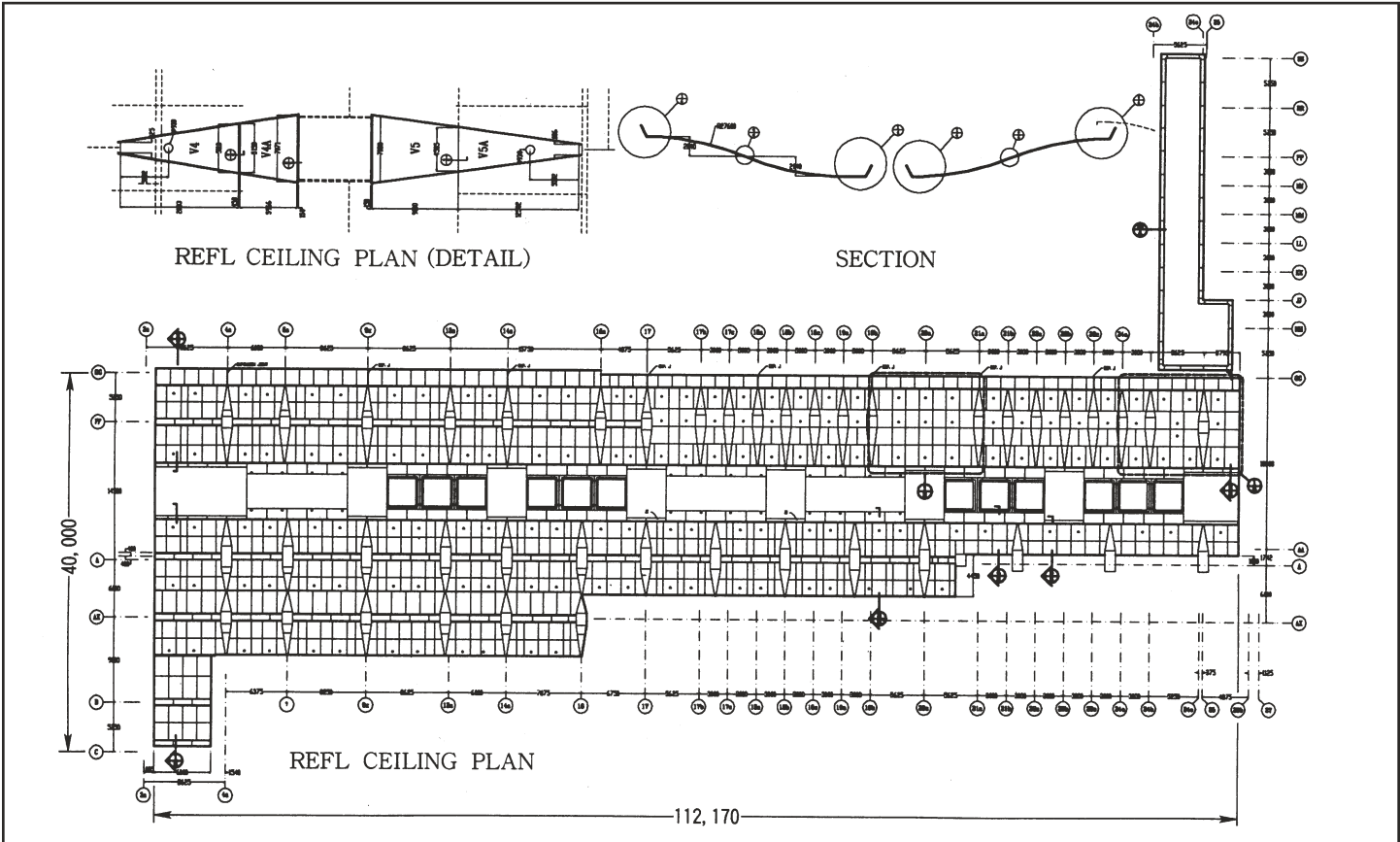



CALLNET (TORONTO)



Details Moulding, Lightcovers & Reflectors

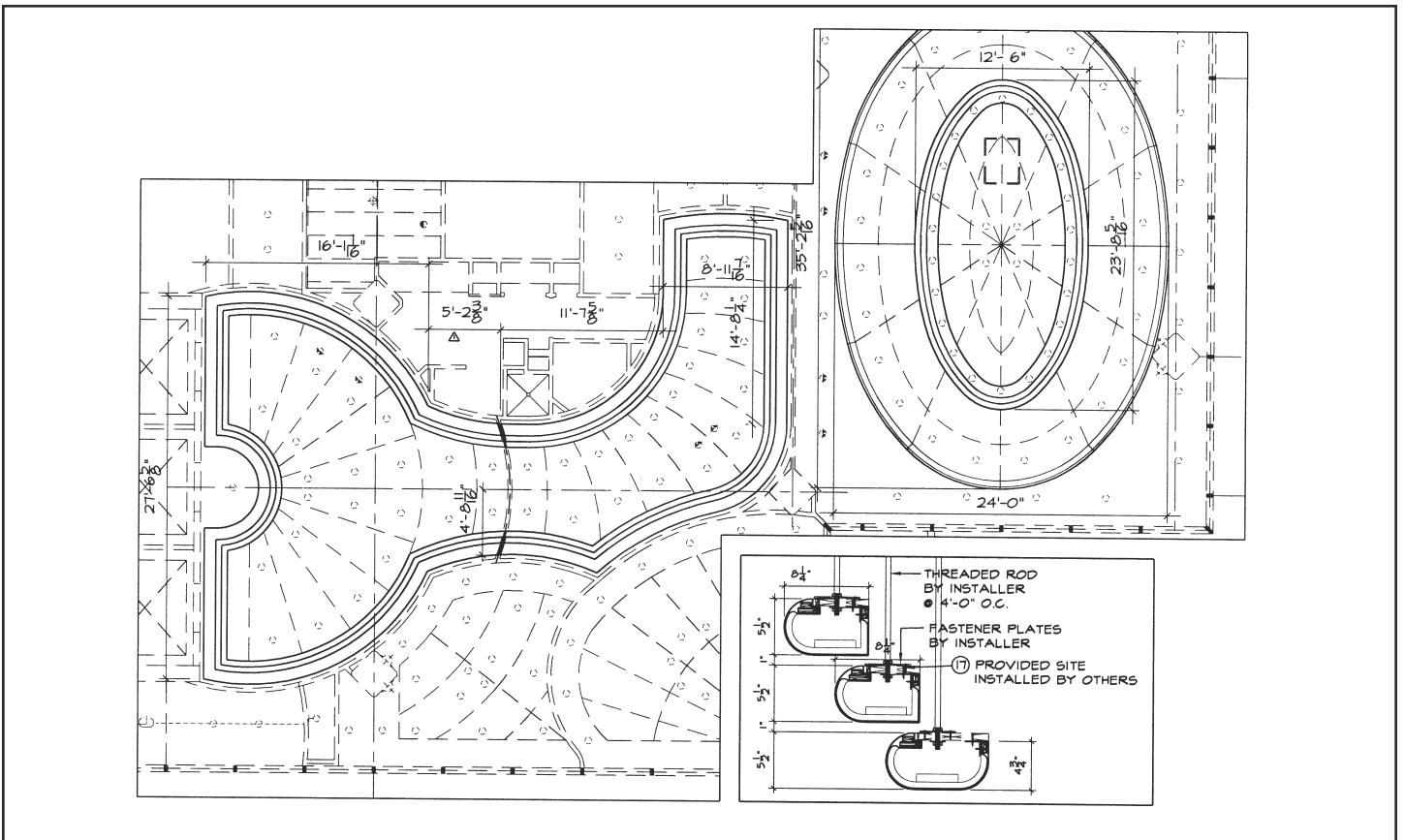



NEW YORK STOCK EXCHANGE (NEW YORK)

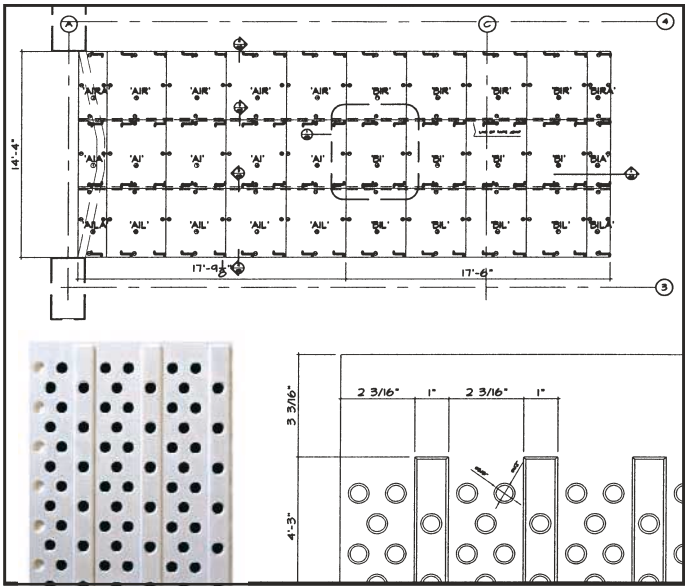

BOND BUILDING (WASHINGTON D.C.)

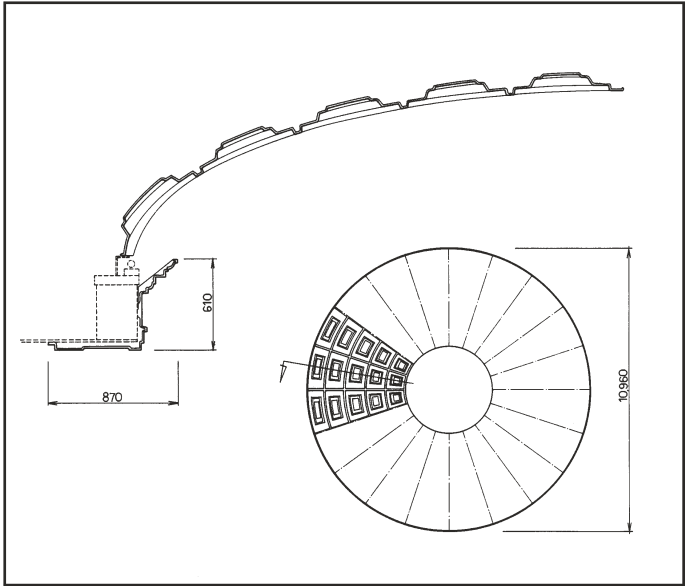

CANADA TRUST B.C.E. PLACE (TORONTO)

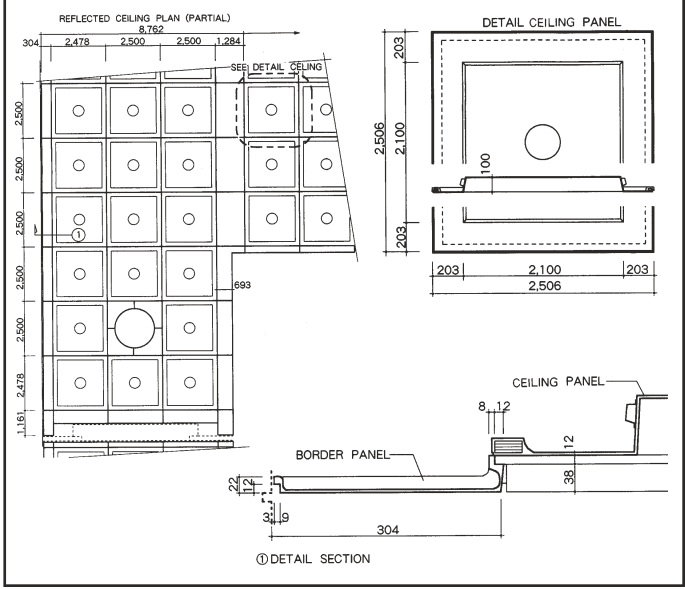



WESTIN HOTEL (KAUAI)

Columns



CINEMA GUZZO (QUEBEC)



SHERWAY GARDENS (TORONTO)



SEGA CITY (TORONTO)



SHERIDAN MALL (PICKERING-ONTARIO)



WINDSOR CASINO (WINDSOR)



CONINTHIAN COLUMN



SHANNON MALL (GEORGIA)



WESTIN HOTEL (TOKYO)

Mouldings



WESTIN HOTEL (HAWAII)



ATLANTIS HOTEL AND CASINO RESORT • LOBBY (NASSAU)



HARTMARX STORE (NEW YORK)



PEPSICO LEADERSHIP CONFERENCE CENTRE (PURCHASE, NY)

Ceilings



CINEPLEX ODEON (TORONTO)



OFFICE ENTRANCE (SAN FRANCISCO)



MEOW RESTAURANT (TORONTO)

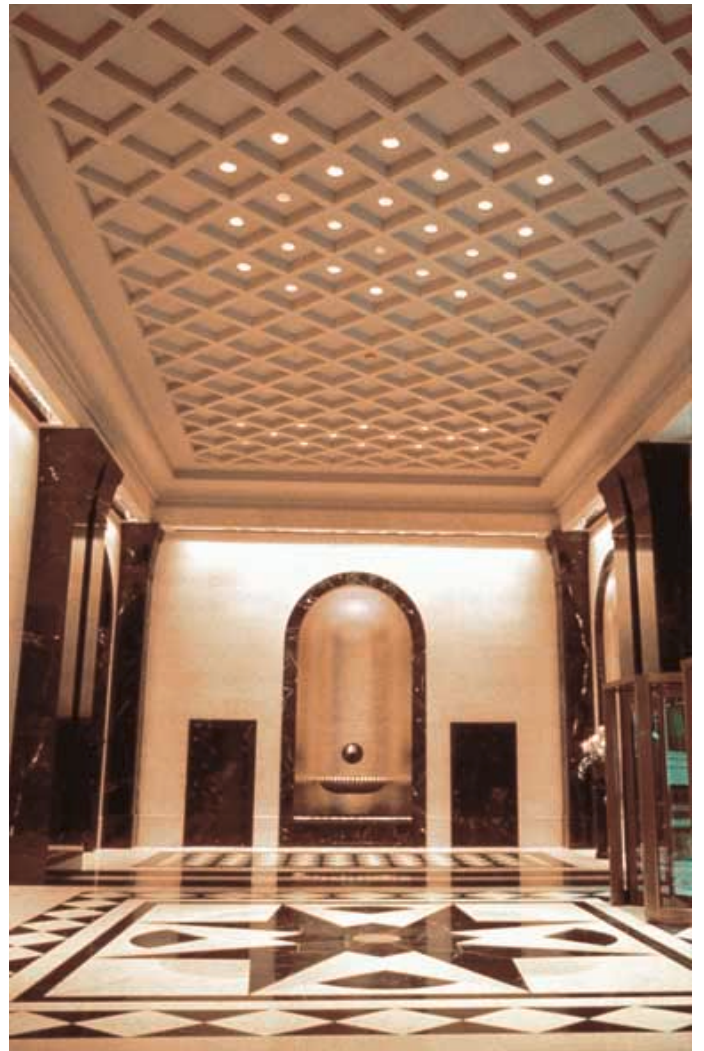

LOBBY • 500 BOYLSTON STREET (BOSTON)



PROFFITS (HAMPTON, VA)

Reflectors & Lightcovers



CALL NET (TORONTO)



WESTIN HOTEL (TOKYO)



WESTIN HOTEL (TOKYO)



GRANITE CLUB (TORONTO)



WESTIN HOTEL (OSAKA)



THE BAY DEPARTMENT STORE (TORONTO)



SHERATON HOTEL - TYSONS CORNER (VIRGINIA)



WESTIN HOTEL (OSAKA)



EQUITABLE LIFE INSURANCE COMPANY • BOARDROOM (NEW YORK)

Vaulted Ceilings



SUNLIFE CAFETERIA (TORONTO)

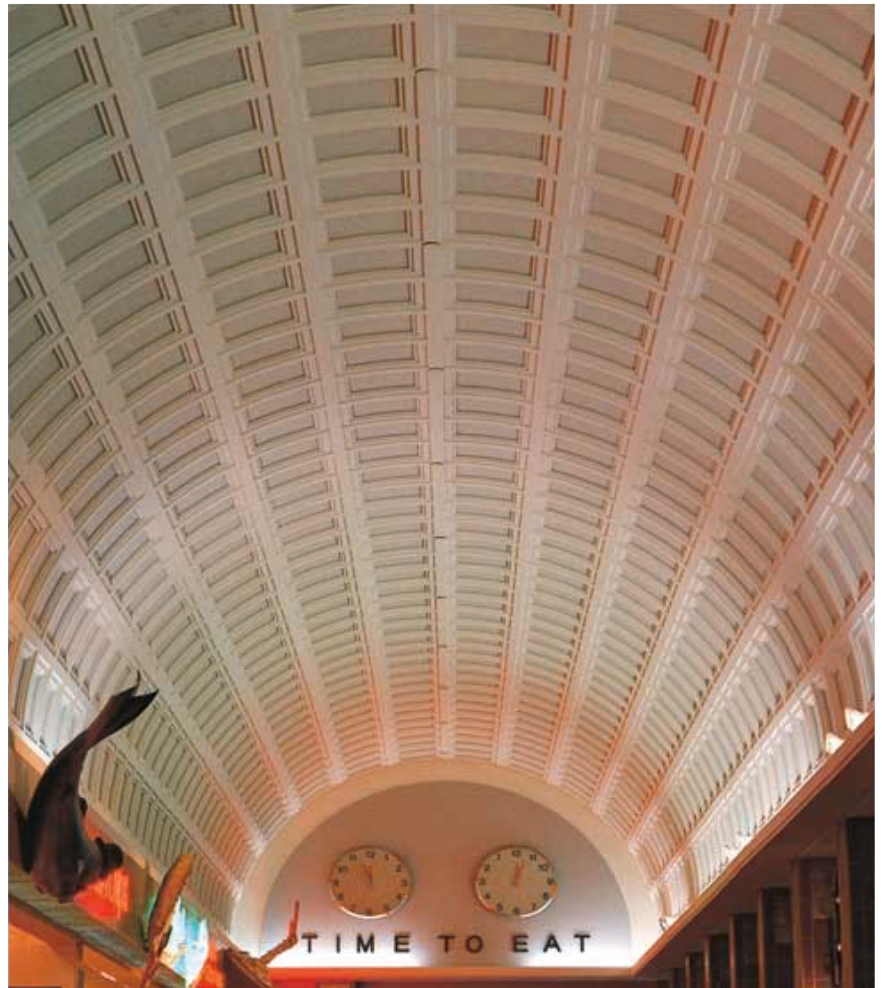

YORKDALE SHOPPING CENTER • FOOD COURT (TORONTO)



CINEPLEX ODEON (TORONTO)

Special Projects



DISNEY STOREFRONT (VARIOUS)



AL GHURAIR (DUBAI, UAE)



WINDSOR CASINO (WINDSOR)

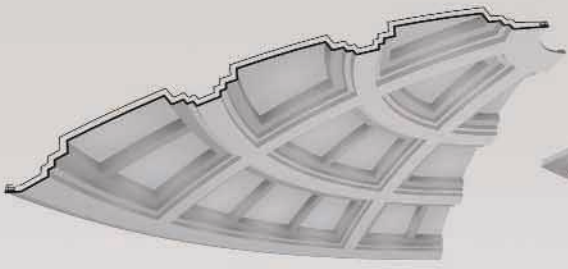

Design — (1)

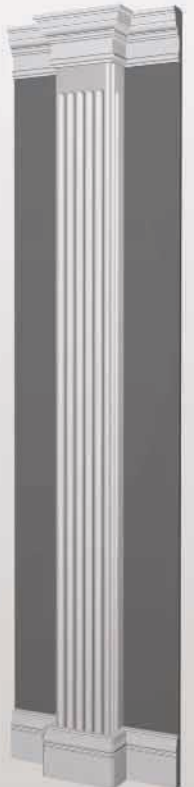
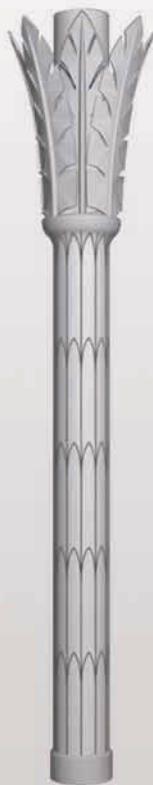
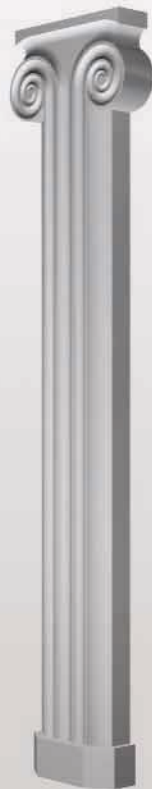
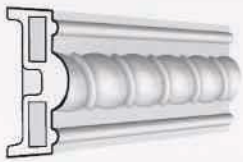
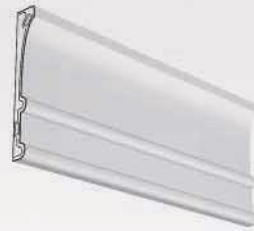
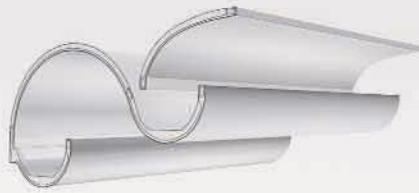

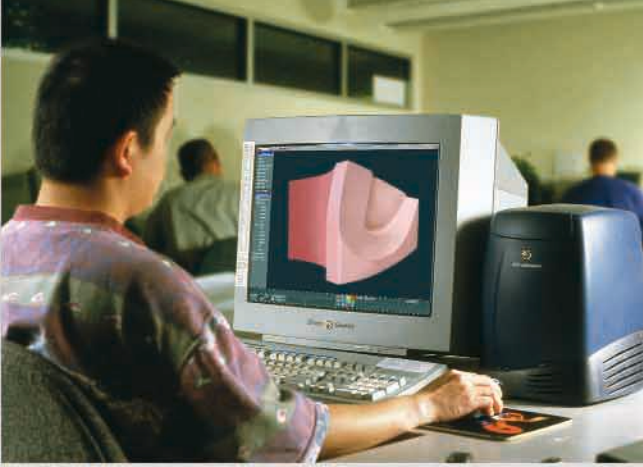

①

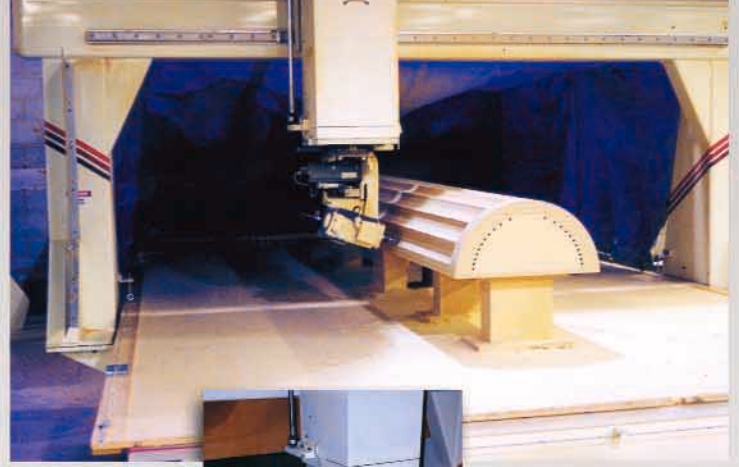

②



③



④

G.R.G. MANUFACTURING PROCESS

- ① Formglas C.A.D. generated shop drawings, (showing parts and installation methods) are submitted for approval.
- ② After approval, advanced C.A.M. equipment cuts patterns that look identical to the final parts.
- ③ 'Mirror Image' molds (shown in red) are fabricated from the patterns.

White, high strength 'alpha' gypsum and glassfiber mat is then hand applied to the molds. Metal or plywood strip reinforcement is incorporated at the same time.

- ④ Once the gypsum has set, the strong 1/8" - 3/16" (3-5mm) thick parts are removed from the molds, then quality inspected and stored.

- QuarryCast® and MetalCast® are, in principle, made the same way as G.R.G. but with the cast-in finishes they are factory sanded, sealed and lacquered.

Note: G.R.G. parts are thin but rigid and cannot be bent. Every curved or radiused element requires it's own pattern/mold.

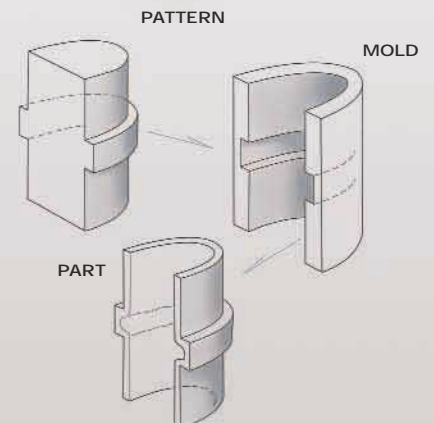

<u>Country</u>	<u>Testing Agency</u>	<u>Test Method/Standard</u>	<u>Certificate</u>	<u>Type of Test</u>	<u>Material</u>
Canada	Ortech International	CAN-S114-M80			
	Ortech International	ASTM-E84-94	Flame 0 Smoke 6	Surface Burning Characteristics	MetalCast
	Intertek Testing Service	CAN/ULC S-102-M88	Flame 3 Smoke 6	Surface Burning Characteristics	QuarryCast E
	Ortech International	ASTM C501	96-T16-U4954-39	Hardness & Abrasion	All Formglas Products
France	CSTB		MO No RA99-076	Burning Characteristics	GRG
	CSTB		MO No RA99-076	Burning Characteristics	QuarryCast
	CSTB		MO No RA99-076	Burning Characteristics	MetalCast
Germany	MPA - NRW	DIN 4102-1(Mai 1998)	A1 No 23000982-2	Burning Characteristics	QuarryCast
	MPA - NRW	DIN 4102-1(Mai 1998)	A2 No 23000982-3	Burning Characteristics	MetalCast
	MPA - NRW	DIN 4102-1(Mai 1998)	A1 No 23000982-1	Burning Characteristics	GRG
	Germanischer Lloyd		15-569-00 HH	Non Combustible - Type Approval Certificate	QuarryCast
	Germanischer Lloyd		15-568-00 HH	Non Combustible - Type Approval Certificate	GRG
Hong Kong	Facadeteck	Safety test of GRC Moldings		Structural Adequacy Test (Cyclic)	Formglas EP
Japan	Ministry of Construction		1142	Certificate of Non-Combustibility	QuarryCast
	Ministry of Construction		11589	Certificate of Non-Combustibility	GRG
	Ministry of Construction		11916	Certificate of Non-Combustibility	Formglas EP
Norway	SINTEF NBL	IMO Resolution A.472(XII)	250010.10/95.280B	Non-Combustibility Test	QuarryCast
	SINTEF NBL	IMO Resolution A.472(XII)	250010.10/95.280B	Non-Combustibility Test	GRG
	Det Norske Veritas		F15392	Non Combustible - Type Approval Certificate	QuarryCast
	Det Norske Veritas		F15391	Non Combustible - Type Approval Certificate	GRG
Singapore	Singapore Fire Service	BS476 Part 4		Acceptance of Non-Combustibility	QuarryCast
	PSB - Singapore	BS476 Part 4	Ref G61417/B/HT	Non-Combustibility Test	QuarryCast
	SISIR	BS476 Part 4	Ref G 132941/B/SCA	Non-Combustibility Test	Formglas EP
Switzerland	Sicherheitsinstiut		Certificate 20000.6241	Non-Combustibility Test	QuarryCast
UK	Warrington Fire Research	BS 476 Part 6: 1989	No: 102210	Fire Test on building material	Formglas EP
	Warrington Fire Research	BS 476 Part 4: 1970	No: 57898	Fire Propagation Index	QuarryCast
	University of Stanfield	BS 6432 & BS EN 1170	Report 7/22/99	4 Point Bend Testing	Formglas EP
	Department of Transport		SUR22 (Rev 7/92)	Certificate of Acceptability	QuarryCast
	Marine Directorate				
USA	Lloyds Register	IMO Resolution A.472(XII)	MED0050301	EC Examination (Type Approval) Certificate	QuarryCast
	Lloyds Register	IMO Resolution A.472(XII)	MED0050300	EC Examination (Type Approval) Certificate	GRG
	United States Testing Company	ASTM E 72-80	176105	Strength Tests of Panels for Building Construction	Formglas EP
	United States Testing Company	PRO/MT/-LC/SCREEN	04431	Combustion Product inhalation Toxicity Screening	GRG
	Dept. of Buildings-N.Y. City		MEA 211-83-M	Approval of material for use in construction	GRG
	United States Coast Guard		46 CFR Ch1. Subpart 164.009-3c		
	United States Testing Company	ASTM E84-81a	85394	Surface Burning Characteristics of Building Materials	GRG
	United States Testing Company	ASTM E-136	185073-2	Behavior of Materials at 750°C	GRG/Formglas EP
	United States Testing Company	ASTM E-84-86	97937-2	Surface Burning Characteristics of Building Materials	Formglas EP

FORMGLAS LITERATURE

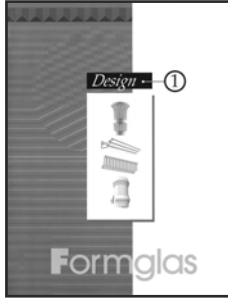

DESIGN ①



QuarryCast®



MetalCast®

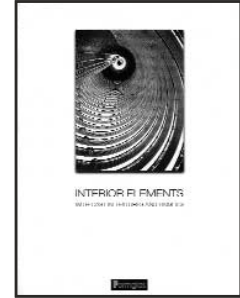

Interior Elements

Formglas Inc.

20 Toro Road, Toronto, ON CANADA M3J 2A7
Tel: (416) 635-8030 Fax: (416) 635-6588
Web Site: [http:// www.formglas.com](http://www.formglas.com)

Formglas (SEA) Sdn Bhd.

Lot 590, Persiaran Raja Lumu Pandamaran Ind. Area,
42000 Port Klang, Selangor Darul Ehsan. Malaysia
Tel: (603) 368-1299 Fax: (603) 367-7795

Formglas Japan Inc.

1-10-4 Shinjuku Shinjuku-Ku, Tokyo 160, JAPAN
Tel: (03) 3225-8397 Fax: (03) 3225-9153